



Umami Blue Moving Coil Phono cartridge Owners Manual

Umami Blue cartridge is Low-Output Type. Operate with Step Up Transformer or MC/Phonostage.

Special Body Finish

The **HANA-Umami Blue** uses a special Melamine Thermosetting Process (MTP) to impart the brilliant blue glossy finish to the Auricle™ body. Developed by Dupont, melamine resin bonds to the aluminum body via a vapor deposition process, baking at 120 degrees Celsius. The Melamine Thermosetting process controls resonances, contributing to the rich sound with increased clarity, better imaging, and bass definition. The luster of the **Umami Blue** glossy finish is brilliant and gorgeous, assuring long life with special optics.

Auricle™ Cartridge body

The **HANA-Umami Blue** incorporates the exclusive Auricle™ body design, first developed for the Umami Red. It mimics the shape of the human outer ear to rigidly support the "Open Air" Moving Coil generator. The unique body shape is machined from A7075 aluminum, one of the strongest and lightest alloys, often specified in aerospace engineering. The **Umami Blue** body features a white POM inlay on its front face to provide damping properties and as homage to the Hana ML, the first cartridge using a POM body. Tapped and threaded mounting holes in the Auricle™ body assure secure attachment to the tonearm.

Enameled Body Treatment

The **HANA-Umami Blue** uses a special enameling process to impart the brilliant blue glossy finish to the Auricle™ body, adding to the rich sound and optics.

Microline stylus

The **HANA-Umami Blue** "nude" natural diamond stylus is cut and polished to mimic the cutting head stylus used to Master or "cut" all vinyl records. This critical part, also used on the HANA-Umami Red, offers the most precise fit into the vinyl groove, tracing the most delicate musical nuances.

Boron cantilever

Boron, with a hardness comparable to diamond, was selected for the **HANA-Umami Blue** to rigidly hold the Microline stylus.

Alnico magnet-based moving coil generator

The Alnico magnet material selected for the **HANA-Umami Blue**, as found in the Hana ML generator, creates a classic sonic quality. Alnico magnets provide greater linearity with reduced saturation, creating a rich musical quality. The Pure copper wires are expertly hand-wound onto the Permalloy cross armature, found in the Hana ML generator. The pure iron pole piece featured in the **Umami Blue** is another key ingredient found in both the HANA-Umami Red and Hana ML generator.

Cryogenic processing

This "cold annealing" process at near absolute zero temperature is used to treat the pole piece, both front and rear yoke in the **HANA-Umami Blue** generator, as well as the gold-plated signal output pins. The cryogenic process alters the molecular structure of the materials, producing a transformative quality similar to molecular gastronomy.

Exceptionally Musical

The Hana team is proud of their seamless integration of brilliant materials, modern audio engineering, and traditional Japanese techniques. Master designer Okada-san brings decades of experience to this design, furthering the Umami concept of synergy with the **HANA-Umami Blue** to create an exceptional musical quality.

Installation

Depending on your headshell / tonearm design, you may wish to fit the cartridge leads before mechanically connecting cartridge to the headshell (see details below and on the right).

Connecting with Headshell

Use the Allen key supplied to tighten both fixing screws into the threaded holes in the cartridge body. Pay careful attention that the cartridge is not twisted or angled when attaching to the headshell. Make sure that there are no foreign objects between the cartridge body and the headshell. Do not use excess force that might strip the screws or distort the body of the cartridge.

We recommend that you use cartridge alignment protractor and tools (not supplied) to ensure the **Umami Blue** cartridge is properly aligned in the headshell and tonearm. For optimum sound quality, it is important to assure correct overhang, offset angle, azimuth and VTA (as with all cartridges). We suggest you get your Hi-Fi Dealer to assist with this if you do not have the correct equipment and skills.

Warranty

The manufacturer's warranty will apply to normal usage and operation for 2 years after purchase date or shipping date from the manufacturer at Excel's discretion. The warranty does not apply to any damage from abuse. This will be determined by manufacturer for warranty eligibility. The warranty covers defects in materials and craftsmanship, but not abuse or wear of stylus tip due to use. Please handle your **Umami Blue** cartridge carefully. Do not use excess force when installing or cleaning your cartridge. If you are unsure, please ask your Dealer for assistance.

If you accidentally damage your cartridge, the manufacturer does offer a generous retip replacement plan. This also applies to cartridges that are out of the warranty period.

Connecting with signal lead out wires

Slide headshell lead wire clips over each **Umami Blue** terminal pins, reminding you to carefully expand clip if needed to best suit pin size.

Red : Right positive (+)

Green : Right negative (-)

White : Left positive (+)

Blue : Left negative (-)

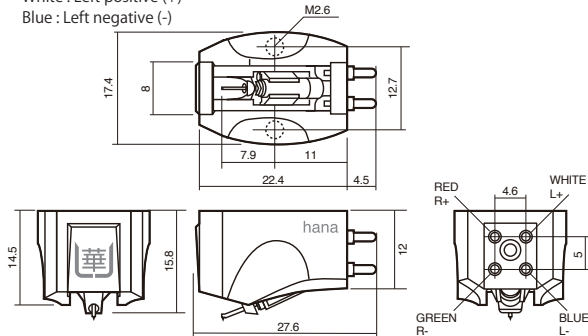

VTF (Vertical Tracking Force) setting:

Nominal VTF is 2.0g for **Umami Blue**.

Note: Increase the VTF value slightly if the room temperature is below 20 degrees Centigrade (68 degrees Fahrenheit). However, the cartridge will warm up after playing music for a few minutes, increasing compliance slightly due to the kinetic energy of the disk.

Caution

● Be sure not to damage vulnerable cantilever or stylus when connecting to headshell. Keep the stylus protector fitted when attaching to headshell.

● Never solder headshell lead wires directly to **Umami Blue** terminal pins as this may damage inner cartridge moving coil wires.

● Do not put any unnecessary pressure on cantilever/stylus with fingers, which is carefully tuned at the factory. Unusual pressure will cause moving coil cartridges to lose their factory set compliance.

To clean the stylus, use the included small brush. Gently move the brush from back to front (moving from cantilever base to stylus tip) to remove dust or debris build up during playback.



Important cartridge fixing instructions:

As illustrated right: Select the correct length of 2.6M screw (4mm, 5mm, 6mm, 8mm lengths provided) to suit your tonearm's headshell thickness.

The depth of threaded holes in Umami body is only 3mm. Using too long of a screw could damage the cartridge when tightening.

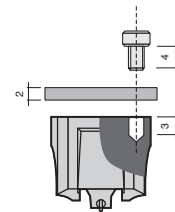

Umami Blue Moving Coil Cartridge Specification

Body	Material	Duralumin (A7075)
	Finish	Melamine Thermosetting Process (MTP)
Cantilever Assy	Cantilever	Boron
	Stylus	Microline Nude Diamond
Magnetic Circuit	Armature Material	Permalloy
	Armature Shape	Cross Plate
	Parts Material	Pure Iron
Coil	Magnet	Alnico (Al-Ni-Co)
	Output Pins	24K Gold Plated
	Coil Impedance	8 Ω
	Output	0.4mV
	Coil Wire Material	High Purity Copper
Treatment	Load Impedance	> 80 Ω
	Cryogenic	Front Yoke, Rear Yoke, Pole Piece, Terminal Pins
Specification	Frequency Response	15-50,000Hz
	Output Balance	0.5dB/1KHz
	Channel Separation	30dB/1KHz
	Tracking Force	2g
	Trackability	70 μm/2g
	Dynamic Compliance	10 × 10 ⁻⁶ cm/dyne (100Hz) Estimated at 17 × 10 ⁻⁶ cm/dyne at 10Hz
Cartridge Weight	10.8g	

Printed in japan