

(華) HANA – MH,ML Moving Coil Phono cartridges Owners Manual

Thank you for purchasing this HANA MH or ML (high or low output) Moving Coil cartridge.

This HANA M range are the advanced models of the now world-wide popular

HANA E and S ranges of Moving Coil cartridges,

famous for their high quality sound reproduction, ease of setup and use; and competitive pricing.

■The M range product line:

HANA-MH: High output/ Micro line stylus to be connected into MM (moving magnet) phono stage

HANA-ML: Low output/ Micro line stylus to be connected with step-up device and MM, or MC phono stage

■Advanced product features (Over E and S range HANA Moving Coil cartridges)

The M range cartridges improve upon the less expensive HANA ranges in several ways, continuing to offer a superb sound quality at their price point.

(A) Stylus design - is 'Micro Line', fitting more precisely into the vinyl groove to capture the very smallest details in the vinyl groove, offering better frequency reproduction and less distortion.

(B) Cartridge body - is manufactured from Delrin® a more rigid plastic material with much improved mechanical characteristics such as better resonance damping and hardness.

(C) Cryogenic processing - (Cold Annealing at near absolute zero temperature restructures metals at the molecular level, resulting in lower sound distortion). Parts such as the front yoke, center and rear components of the magnetic electro-motive circuit are treated. The result is a more precise and musical sound quality.

(D) Very high-Purity copper wire - has been selected for MH/ML moving coils, offering greater clarity of sound, thanks to its lower distortion of the musical signal.

(E) Captive threaded nuts - for head shell fixing screws, are built into the cartridge body offering easy mechanical fixing to the Tonearm headshell.

■Installation

Depending on your headshell / tonearm design, you may wish to fit the leadout wires before mechanically connecting cartridge to the headshell (see details below).

●Connecting with Headshell

Make sure that there are no foreign objects between the cartridge body and the headshell before fitting. Use the Allen key supplied to tighten both fixing screws into the captive nuts in the cartridge body. Pay careful attention that the cartridge is not twisted or angled when attaching to the headshell. Do not use excess force that might strip the screws or distort the body of the cartridge.

We recommend that you use cartridge fitting adjustment guides and tools (not supplied) to ensure the HANA cartridge is properly aligned in the headshell. For optimum sound quality, it is important to achieve correct azimuth and zenith, and to assure correct offset angle and geometry (as with all cartridges). We suggest you get your Hi-Fi Dealer to help with this if you do not have the correct equipment yourself.

●Connecting with signal lead out wires

Slide head-shell lead wire tags over to each HANA terminal pins, reminding you to expand tag inlet a little to suite to pin size.

Red : Right positive (+)
Green : Right negative (-)
White : Left positive (+)
Blue : Left negative (-)

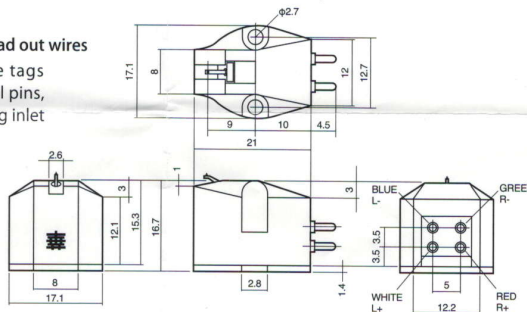

●VTF (Vertical Tracking Force) setting:

Nominal VTF is 2.0g for all HANA models.

Note: Increase the VTF value slightly if the room temperature is below 20 degrees Centigrade (68 degrees Fahrenheit). However, the cartridge will warm up after playing music for a few minutes, increasing compliance slightly due to the kinetic energy of the disk.

■Caution

●Be sure not to damage vulnerable cantilever or stylus when connecting with headshell. Keep the stylus protector fitted whilst attaching to headshell.

●Never solder headshell lead wires directly to HANA terminal pins, this may break inner cartridge moving coil wires.

●Do not put any unnecessary pressure on cantilever stylus with fingers, which is carefully tuned at the factory. Unusual pressure will cause moving coil cartridges to lose their factory set compliance. To clean the stylus, use the included small brush. Gently move the brush from back to front (moving from cantilever base, to stylus tip) to remove dust or debris, built up during playback.

■Warranty

The manufacturer's warranty will apply to normal usage and operation for 2 years after shipping date from the manufacturer. However, the warranty does not apply to any damage by abuse. This is to be determined by manufacturer for warranty eligibility. The warranty covers defects in materials and craftsmanship, but not abuse or wear of stylus tip due to use. Please handle your HANA cartridge carefully. Do not use excess force when installing or cleaning your cartridge. If you are unsure, please ask your Dealer for assistance.

If you accidentally damage your cartridge, the manufacturer does offer a generous retip plan. This also applies to cartridges that are out of the warranty period.

■Hana Moving Coil Cartridges Specification

Model No.	HANA-MH	HANA-ML
Stylus	Nude Microline tip	Nude Microline tip
Cantilever	Aluminum	Aluminum
Magnetic circuitry	Pure Iron/Cryo treatment	Pure Iron/Cryo treatment
Coil wire	High Purity Copper	High Purity Copper
Cartridge Housing	POM(Delrin®)	POM(Delrin®)
Output level	2mv/1KHz	0.4mv/1KHz
Output balance	<1dB/1KHz	<1dB/1KHz
Trackability	70 μ/2gr	70 μ/2gr
Channel separation	30dB/1KHz	30dB/1KHz
Frequency response	12-45,000Hz	12-45,000Hz
Impedance	130Ω/1KHz	7Ω/1KHz
Suggested load Impedance	47kΩ	>100Ω